

EATON

COUPLINGS

AA

40

Supersedes AEB-66

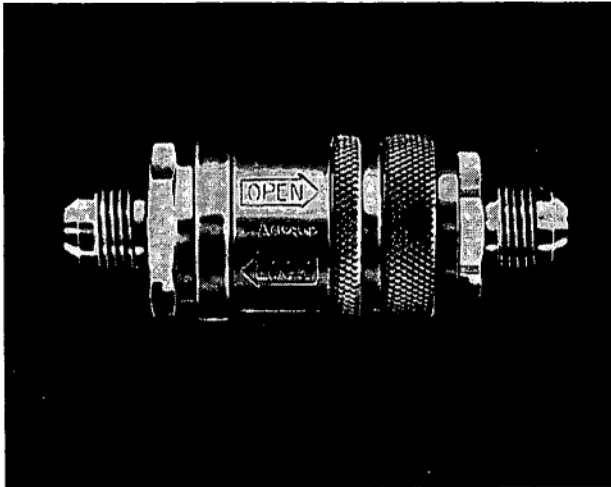

- 1 Positive valve operation
- 2 Non-spill—no spray design
- 3 Minimum air inclusion and fluid loss
- 4 Push-Pull operation
- 5 Lowest pressure loss (only 1½ psi @ 6 gpm) —8 size
- 6 Easily adapted to remote operation
- 7 Low force required to connect

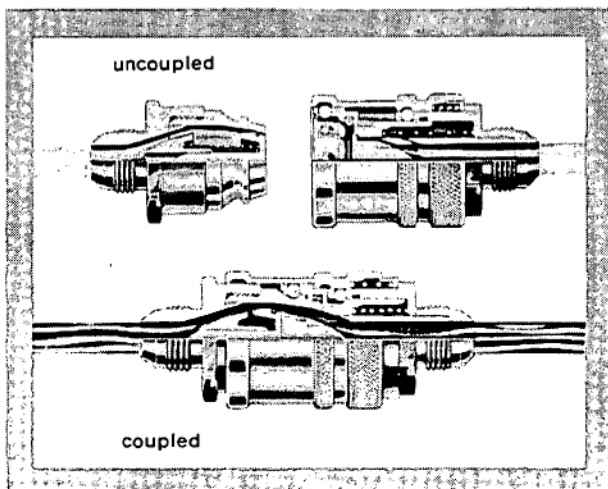

Aeroquip 3900 Series Quick-Disconnect Couplings

provide safety and reliability for Aircraft, Missile and GSE applications using standard or special fluids at pressures up to 1000 psi.

The 3900 Series Coupling is a self-sealing, quick-disconnect coupling specifically designed for maximum reliability and safety when used with normally hard-to-handle fluids. It eliminates spillage, leakage or spraying during connection and disconnection by employing a unique mechanically actuated sleeve. This sleeve overcomes the usual limitations of dynamic reciprocating seals used with low lubricity fluids.

Principal of Operation

The 3900 series coupling is easily connected with one hand by a simple push together motion requiring no twisting, turning, or cocking. The mating halves are completely sealed by an "O" ring *before* the valves are opened. A positive lock is obtained through two sets of locking balls in the hose attaching half of the coupling, one of which engages the ball race of the bulkhead half when fully connected. The coupling may be disconnected by an equally simple pulling motion of the union sleeve. This motion positively closes and seals the coupling valves *before* disconnection has occurred. This is accomplished by the set of locking balls incorporated as an integral part of the sleeve valve in the hose attaching half, which will not release until the sleeve has been mechanically pulled shut and sealed.

The push-pull feature, with the mechanically closed positive seal with no spillage/air inclusion makes the design ideally suited to various remote disconnect methods such as solenoid, lanyard or pneumatic.

Coupling styles and Part numbers

Aeroquip 3900 Series Couplings are available with various end fitting combinations. Select the base part number for the desired style of complete coupling assembly or for the coupling halves from the table at right and complete the part number as shown on page 4.

Application	FUEL	OIL	COOLANT
Specification	MIL-C-7413A Type I	MIL-C-7413A Type II	Ethylene Glycol Solution
Coupling half, Bulkhead mounting	390210	390206	3902
Coupling assembly	390008	390055	3900
Coupling half, Hose attaching	390509	390505	3905

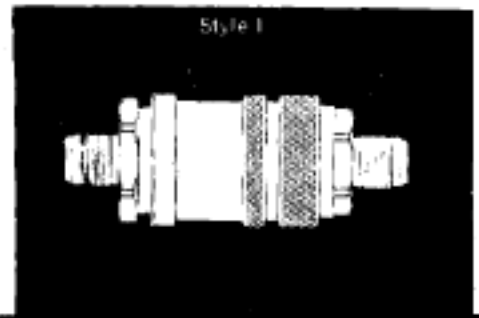

COMPONENT PARTS

MATERIAL
ALUMINUM
STAINLESS STEEL

ITEMS
① ② ③ ④ ⑤ ⑥
⑦ ⑧ ⑨ ⑩

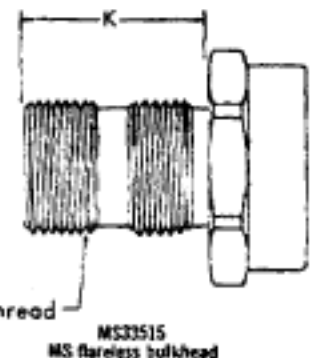
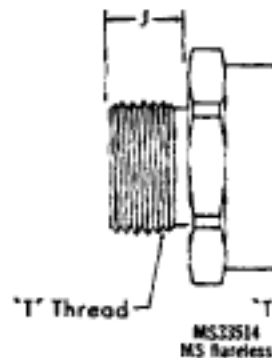
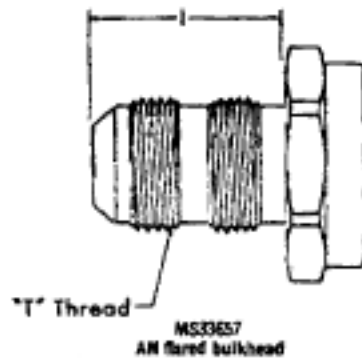
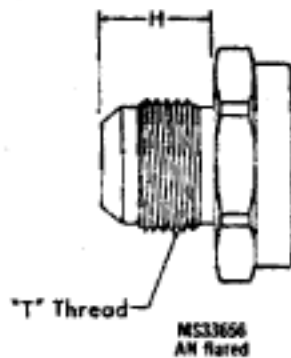
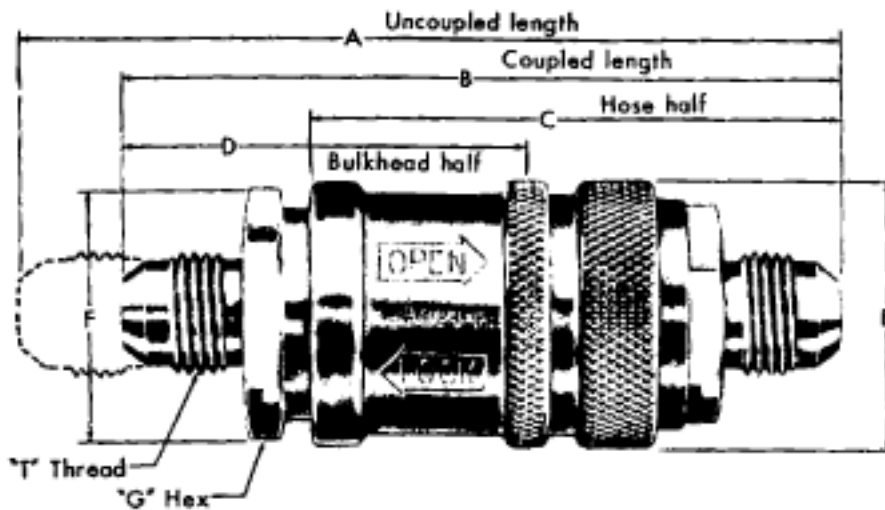
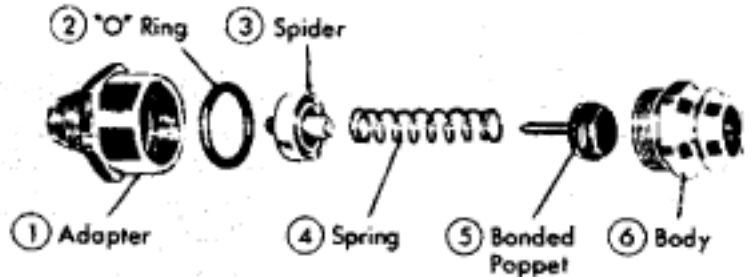

Style II



Style III



	Style II				Style III			
	FUEL	OIL	COOLANTS		FUEL	OIL	COOLANTS	
anol & 35	MIL-C-7413A Type I	MIL-C-7413A Type II	Ethylene Glycol Solution	Coolanol 25 & 35	MIL-C-7413A Type I	MIL-C-7413A Type II	Ethylene Glycol Solution	Coolanol 25 & 35
261	390212	390213	390202	390275	390216	390217	390204	390254
059	390010	390058	390012	390060	390016	390017	390018	390061
544	390509	390505	3905	390544	390511	390512	390503	390563

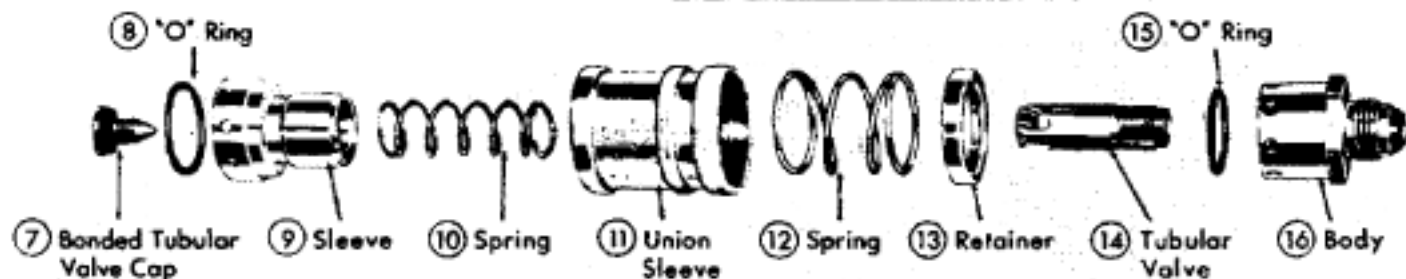

Dash Size →	-4	-6	-8	-10	-12	-16
Tube Size →	¼	⅜	½	¾	1	1 ¼

	DIMENSIONS (INCHES)	Dash Size					
		-4	-6	-8	-10	-12	-16
WEIGHT (LBS.)	A	3.67	4.07	4.82	5.23	5.56	6.90
	B	2.95	3.26	3.82	4.17	4.47	5.27
	C	2.04	2.28	2.72	3.01	3.16	3.84
	D	1.58	1.74	2.04	2.16	2.34	2.77
	Style I	.14	.23	.44	.50	.65	1.31
	Style II	.15	.24	.46	.52	.68	1.36
	Style III	.15	.24	.45	.51	.67	1.34
	E Dia.	1.00	1.20	1.50	1.55	1.75	2.25
	F	.90	1.11	1.40	1.44	1.65	2.23
	G Hex.	.81	1.00	1.25	1.31	1.50	2.00
	H	.550	.556	.657	.758	.864	.911
I	1.047	1.125	1.281	1.422	1.593	1.593	
J	.453	.469	.562	.625	.688	.688	
K	.969	1.015	1.156	1.297	1.406	1.406	
"T" Thread		¼-20 UNF	⅜-18 UNF	½-16 UNF	¾-14 UNF	1 ¼-12 UN	1 ½-12 UN

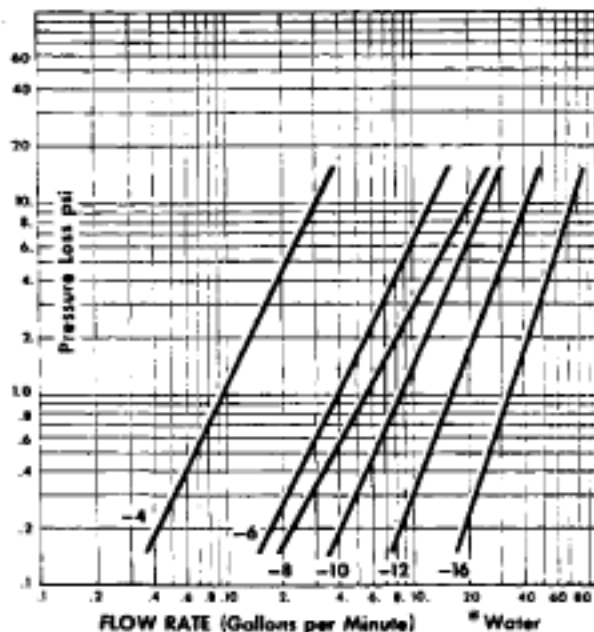

Operation of the Aeroquip 3900 Series is simple and positive. A mechanically actuated sleeve valve overcomes the limitations of a sliding seal and makes possible a no-air inclusion, no-fluid loss Self-Sealing Coupling for many new applications, with difficult to handle fluids.

Couplings can be furnished with special packings and body materials for a variety of fluids or gases. Other end fittings or connection variations may be designed for special coupling situations such as remote operation. Contact your Aeroquip representative or send details of your application for engineering assistance.

How to complete Part number

3900-8 = Complete coupling part number
 — base number
 — dash size (tube O. D. in 1/16")

Pressure loss versus flow

Pressure loss and flow characteristics of the 3900 Series are superior to any valved coupling available to date. A glance at the cutaway illustration shows how these features are obtained by careful proportioning, streamlined valves, and avoidance of exposed springs and abrupt changes in the flow pattern. This superior flow pattern makes possible smaller line sizes, smaller pump capacity and other improvements in the system.

To find the pressure loss for a given coupling size at a given flow rate, 1) find flow rate at bottom of chart and read up until line intersects the curve for the coupling size in question, 2) read across to find the pressure loss. Data in chart at left is plotted for water at 70°F to 90°F.

Specifications

Operating Temperatures:*	continuous	intermittent
	Fuel	-65° to +160°F
Synthetic oil (MIL-L-7808)	-65° to +325°F	-65° to +375°F
Coolant (ethylene glycol solution)	-65° to +275°F	-

Pressure Data (psi):	operating	proof	burst
	Sizes -4 thru -16	1000	1500

Force to connect (-8 size):	line pressure on:	hose half	bulkhead half
		0	25 lbs.
	50 psi	50 lbs.	40 lbs.
	100 psi	80 lbs.	62 lbs.
	150 psi	110 lbs.	85 lbs.

NOTE: Data on other sizes available on request.

Suggested applications and fluids:*	Fuel systems
	Oil systems
Hydraulic return systems	

Electronic Cooling:	glycol solutions	Coolanol 25 & 35
	deionized water	FC-75

Acids and many other corrosive or hazardous fluids.

*With appropriate changes in materials and packings, couplings may be adapted to a wide range of fluids and temperature ranges.

EATON

Eaton Corporation
 Fluid Conveyance
 300 S. East Avenue, Jackson, MI 49203-1972
 Phone: 517-787-8121, Fax: 517-787-5758
 www.aerospace.eaton.com

Specifications subject to change without notice. Aeroquip products are protected by patents internationally.